

vertical

increase
safety

ergonomic

customizable

STORAGE

fully automated

carousel

quick retrieval time

small footprint

high volume

Shelving Carousel



Vidir Machine is a leading manufacturer and worldwide supplier of automated storage and retrieval carousels. Our highly versatile line of products offers industry solutions for construction, retail, medical, warehouse, government, automotive, printing and manufacturing. Vertical Carousels take advantage of unused overhead space to save space, increase productivity, and improve workplace safety.

Vidir is a family business that was founded in 1979 to service the local ag industry but in 1985 when two family members were looking for a convenient way to store and display their rolls of vinyl flooring they turned to their dad for a solution. In 1986 the first carousel (which is still in operation today) was built and 30 years later, Vidir products can be found worldwide in over 30 different countries.



Today's Presenter



Dean Dueck
Marketing Manager

Safe Handling • Easy Access • Maximum Storage • Fast Retrieval • Small Footprint



Vidir Quick Facts

- 135 employees over 3 locations in Canada and the US
- 35,000 + system installations around the world
- Installations in over 30 countries worldwide
- Over 10% of Vidir's employees are in product development.
- Family owned business.

Locations

Head Office: Arborg, Manitoba, Canada

PO Box 700
8126 Road 138 North
Arborg, MB, Canada R0C 0A0

Teulon, Manitoba, Canada

PO Box 131
379 1st Street
Teulon, MB, Canada R0C 3B0

Lebanon, Pennsylvania, United State

19 East Lehman Street
Lebanon, Pennsylvania, United States 17046

Safe Handling • Easy Access • Maximum Storage • Fast Retrieval • Small Footprint



Webinar Summary



- ✓ **Shelving Carousel Overview**
- ✓ **What To Look For**
- ✓ **Applications**
- ✓ **Discovery Phase**
- ✓ **Specification Phase**
- ✓ **Logistics Phase**
- ✓ **Service Questions**

Safe Handling • Easy Access • Maximum Storage • Fast Retrieval • Small Footprint

What is a Shelving Carousel?

Vidir's Shelving Carousel is a highly flexible semi/fully automated vertical carousel designed to provide high storage density for bulky and heavier items. This automated storage system works by delivering the product directly to the operator, eliminating climbing and bending to retrieve heavy and bulky items.



Safe Handling • Easy Access • Maximum Storage • Fast Retrieval • Small Footprint

Vertical Carousel Primary Selling Points

1 Save Space

2 Increases Safety

3 Increase Security

4 Improves Efficiency

5 Increases Organization



Safe Handling • Easy Access • Maximum Storage • Fast Retrieval • Small Footprint

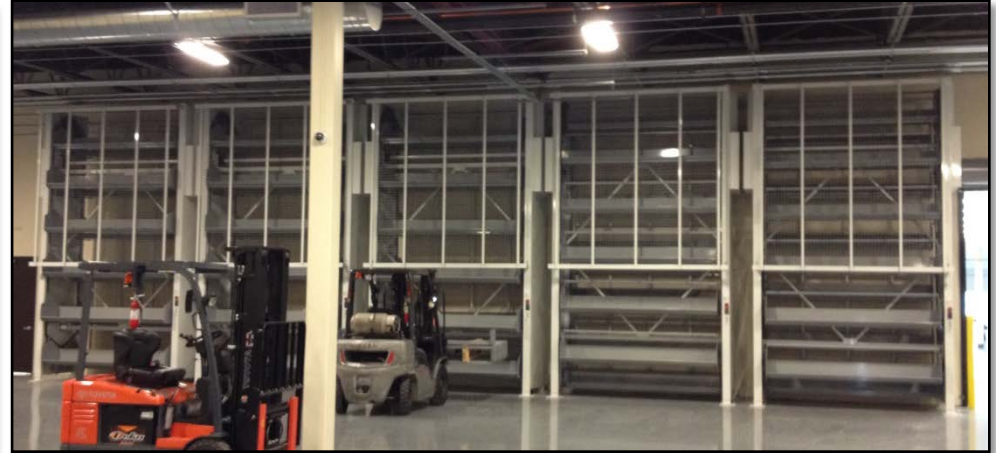

Safe Handling • Easy Access • Maximum Storage • Fast Retrieval • Small Footprint

Storage System

The Shelving Carousel's carriers are attached to the chain by a single reinforced point resulting in a sturdy yet free hanging carrier. This allows the carriers to be customized for unique applications and gives the operator greater flexibility when dealing with large, bulky, or oddly shaped items.

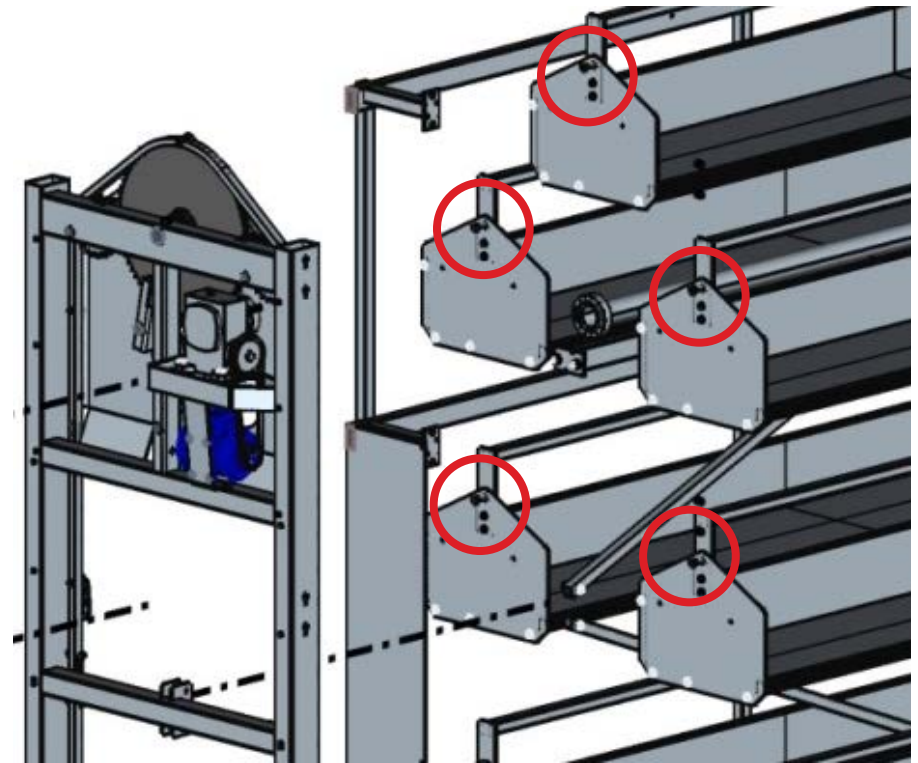

Safe Handling • Easy Access • Maximum Storage • Fast Retrieval • Small Footprint

- A** Side Paneling
- B** Left Carousel Tower
- C** Cross Braces
- D** Drive Shaft
- E** Carriers
- F** Right Carousel Tower
- G** Junction Box
- H** Control Panel
- I** Cross Guards
- J** Upright Guards

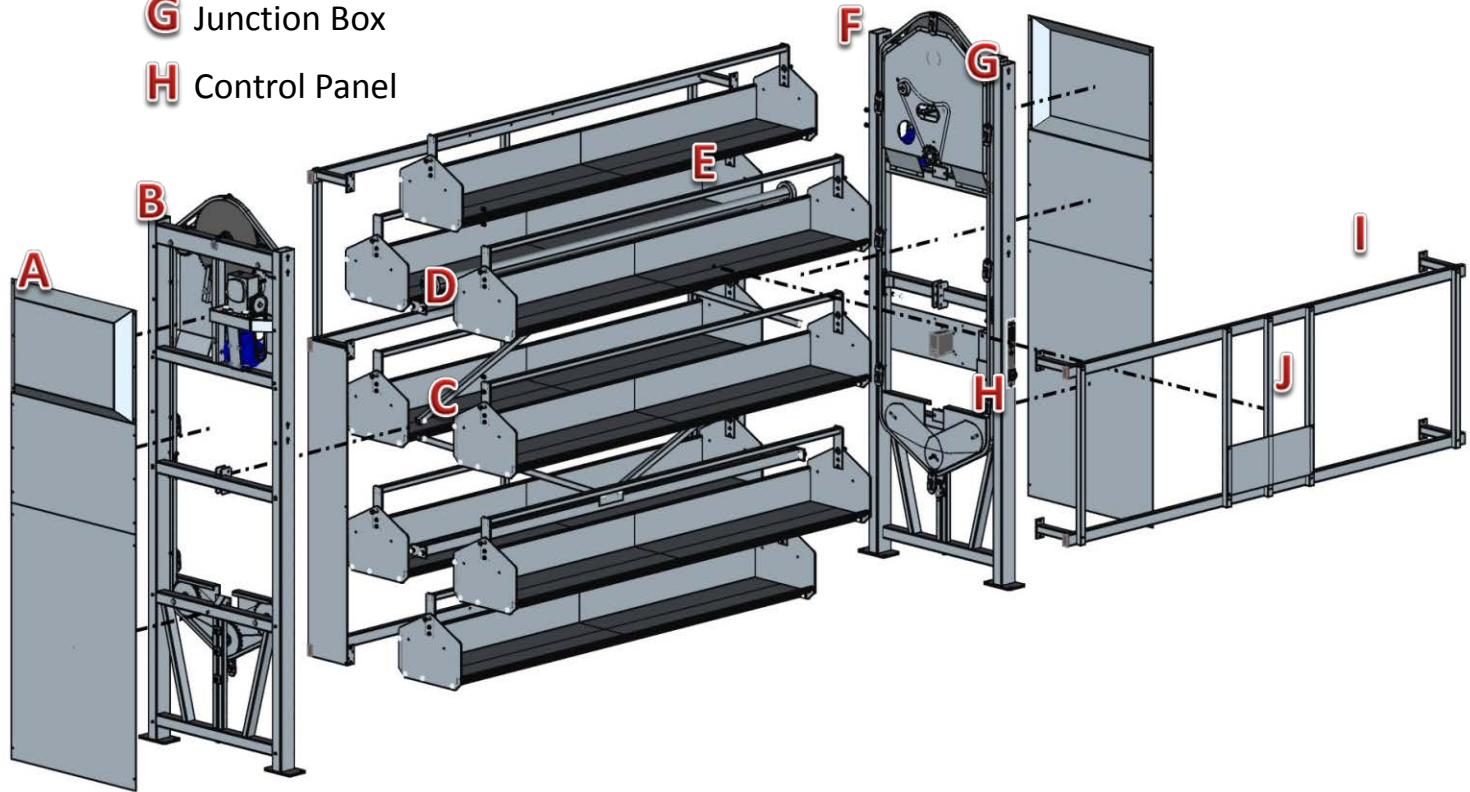

Safe Handling • Easy Access • Maximum Storage • Fast Retrieval • Small Footprint

**For Further Questions on
Vertical Carousel benefits email
robin.chestnut@vidir.com**

Safe Handling • Easy Access • Maximum Storage • Fast Retrieval • Small Footprint

Where Is Your Opportunity?

- ✓ Tall ceilings and material only stored within reaching height.
- ✓ Bulky and difficult items spread on pallets on the floor.
- ✓ Shipping and loading departments. Low value inventory that requires a lot of space.
- ✓ Manufacturing staging areas.
- ✓ Maintenance Departments.
- ✓ Poorly tracked, unorganized, and messy storage.

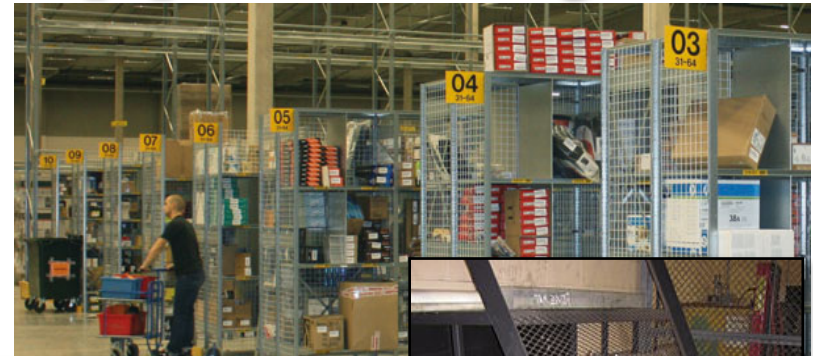

Safe Handling • Easy Access • Maximum Storage • Fast Retrieval • Small Footprint

Who Is Using it?

Industries	Examples of Shelving Carousel Customers
Manufacturing	Heavy Duty Sewing Machinery, Power Management Solutions, Rehab Equipment, Plastic Packaging Material
Automotive	Farm Equipment Dealer, Auto Parts Store, Auto Upholsterer, Racing Car Parts Store
Pharmaceutical	Pharmaceutical Company
Mining	Mining Companies
Electrical	Electrical Supply Store, Lighting Company

Safe Handling • Easy Access • Maximum Storage • Fast Retrieval • Small Footprint

Who To Contact

- R&D Design Engineer
- Materials Manager
- Director of Engineering
- Logistics Manager
- Material Supervisor
- Operations Manager



Safe Handling • Easy Access • Maximum Storage • Fast Retrieval • Small Footprint

3 Phases to the Sales Process

Discovery Phase

Getting information from the customer

Specification Phase

Providing information back to the customer

Logistics Phase

Serious buying signal

Safe Handling • Easy Access • Maximum Storage • Fast Retrieval • Small Footprint

4 Most Important Questions to Ask

1 What is your available ceiling height?

2 What items are you looking to store?

1. Type of product
2. Does it come in a container?
3. Physical Dimensions of the product/container to be stored?
 - A. Height
 - B. Width
 - C. Depth
 - D. Weight
4. Quantity per item/container?

3 How are you currently storing the items?

4 When are you looking to make a decision on this?



Safe Handling • Easy Access • Maximum Storage • Fast Retrieval • Small Footprint

Take Pictures!

When on-site and if the customer allows it take pictures of the product to be stored and the installation location.



Safe Handling • Easy Access • Maximum Storage • Fast Retrieval • Small Footprint

Based on the information received during the discovery phase it is time to

START SPECIFYING A MACHINE TO THE PROJECT.

The first thing you will want to do is determine which size of machine makes the most sense.

Safe Handling • Easy Access • Maximum Storage • Fast Retrieval • Small Footprint

Basic Carousel Package

- ✓ Semi-Automated Controls w/ Keypad
- ✓ Electrical: feeds from top right of carousel
 - ✓ 208/230V, 15 Amp, 60 Hz, 3 Phase
 - ✓ 460/480V, 10 Amp, 60 Hz, 3 Phase
- ✓ 21' per minute retrieval speed
- ✓ Max Load Capacity: 13,000 lbs.
- ✓ Load per Carrier: 1,000 lbs.
- ✓ Variable Frequency Drive (VFD)
- ✓ Maximum Unit Imbalance 1,950 lbs.
- ✓ 2" mesh guarding front and back
- ✓ cCSAus mark
- ✓ Color: White with Grey Interior
- ✓ 1 Year Manufacturers Warranty



“Vertical Storage allows you to utilize your wasted overhead space.”

Safe Handling • Easy Access • Maximum Storage • Fast Retrieval • Small Footprint

S39 Carousel Specifications

*Carrier Dimensions: 104" W x 18.5" H x 20" D

MODEL	HEIGHT	WIDTH	DEPTH	CARRIERS	S. CAPACITY	LIVE LOAD	AVG. CARRIER WEIGHT CAPACITY
S39089-0534-08	7' 6"	10' 7"	5' 1"	05	111.37 ft ³	12,033 lbs.	1,000 lbs.
S39106-0634-08	8' 11"	10' 7"	5' 1"	06	133.49 ft ³	11,836 lbs.	1,000 lbs.
S39123-0734-08	10' 4"	10' 7"	6' 5"	07	156.1 ft ³	11,639 lbs.	1,000 lbs.
S39140-0834-08	11' 9"	10' 7"	6' 5"	08	178.34 ft ³	11,442 lbs.	1,000 lbs.
S39157-0934-08	13' 2"	10' 7"	6' 5"	09	200.59 ft ³	11,245 lbs.	1,000 lbs.
S39174-1034-08	14' 7"	10' 7"	6' 5"	10	222.84 ft ³	11,048 lbs.	1,000 lbs.
S39191-1134-08	16' 0"	10' 7"	6' 5"	11	245.08 ft ³	10,851 lbs.	986 lbs.
S39208-1234-08	17' 5"	10' 7"	6' 5"	12	267.33 ft ³	10,654 lbs.	888 lbs.
S39225-1334-08	18' 10"	10' 7"	6' 5"	13	289.58 ft ³	10,457 lbs.	804 lbs.

Safe Handling • Easy Access • Maximum Storage • Fast Retrieval • Small Footprint

S39 Carousel Specifications

*Carrier Dimensions: 152" W x 18.5" H x 20" D

MODEL	HEIGHT	WIDTH	DEPTH	CARRIERS	S. CAPACITY	LIVE LOAD	AVG. CARRIER WEIGHT CAPACITY
S39089-0534-12	7' 6"	14' 7"	5' 1"	05	162.8 ft ³	11,737 lbs.	1,000 lbs.
S39106-0634-12	8' 11"	14' 7"	5' 1"	06	192.29 ft ³	11,481 lbs.	1,000 lbs.
S39123-0734-12	10' 4"	14' 7"	6' 5"	07	227.78 ft ³	11,225 lbs.	1,000 lbs.
S39140-0834-12	11' 9"	14' 7"	6' 5"	08	260.27 ft ³	10,969 lbs.	1,000 lbs.
S39157-0934-12	13' 2"	14' 7"	6' 5"	09	293.11 ft ³	10,712 lbs.	1,000 lbs.
S39174-1034-12	14' 7"	14' 7"	6' 5"	10	325.60 ft ³	10,456 lbs.	1,000 lbs.
S39191-1134-12	16' 0"	14' 7"	6' 5"	11	358.09 ft ³	10,200 lbs.	927 lbs.
S39208-1234-12	17' 5"	14' 7"	6' 5"	12	390.58 ft ³	9,944 lbs.	829 lbs.
S39225-1334-12	18' 10"	14' 7"	6' 5"	13	423.07 ft ³	9,688 lbs.	745 lbs.

Safe Handling • Easy Access • Maximum Storage • Fast Retrieval • Small Footprint



*General rule of thumb –
the taller the carousel the
more viable the opportunity.*

Safe Handling • Easy Access • Maximum Storage • Fast Retrieval • Small Footprint

The Taller the Carousel the More Efficient the Carousel

S39 Carousel Specifications

*Carrier Dimensions: 152" W x 18.5" H x 20" D

Model	Height	Width	Depth	Carriers	S. Capacity	Live Load	Avg. Carrier Weight Capacity
S39089-0534-12	7' 6"	14' 7"	5' 1"	05	162.8 ft ³	11,737 lbs.	1,000 lbs.
S39106-0634-12	8' 11"	14' 7"	5' 1"	06	192.29 ft ³	11,481 lbs.	1,000 lbs.
S39123-0734-12	10' 4"	14' 7"	6' 5"	07	227.78 ft ³	11,225 lbs.	1,000 lbs.
S39140-0834-12	11' 9"	14' 7"	6' 5"	08	260.27 ft ³	10,969 lbs.	1,000 lbs.
S39157-0934-12	13' 2"	14' 7"	6' 5"	09	293.11 ft ³	10,712 lbs.	1,000 lbs.
S39174-1034-12	14' 7"	14' 7"	6' 5"	10	325.60 ft ³	10,456 lbs.	1,000 lbs.
S39191-1134-12	16' 0"	14' 7"	6' 5"	11	358.09 ft ³	10,200 lbs.	927 lbs.
S39208-1234-12	17' 5"	14' 7"	6' 5"	12	390.58 ft ³	9,944 lbs.	829 lbs.
S39225-1334-12	18' 10"	14' 7"	6' 5"	13	423.07 ft ³	9,688 lbs.	745 lbs.

Safe Handling • Easy Access • Maximum Storage • Fast Retrieval • Small Footprint

Shelving Carriers Standard

A standard open carrier for the shelving carousel is 18.5" H x 20" D and provides flexibility whether storing SKU's directly on the carrier, using standard containers, or application specific containers to best utilize the available space.



Safe Handling • Easy Access • Maximum Storage • Fast Retrieval • Small Footprint

Shelving Carriers Standard Configurations

Intermediary shelves and dividers are available to partition the carrier to create internal storage compartments for better organization.

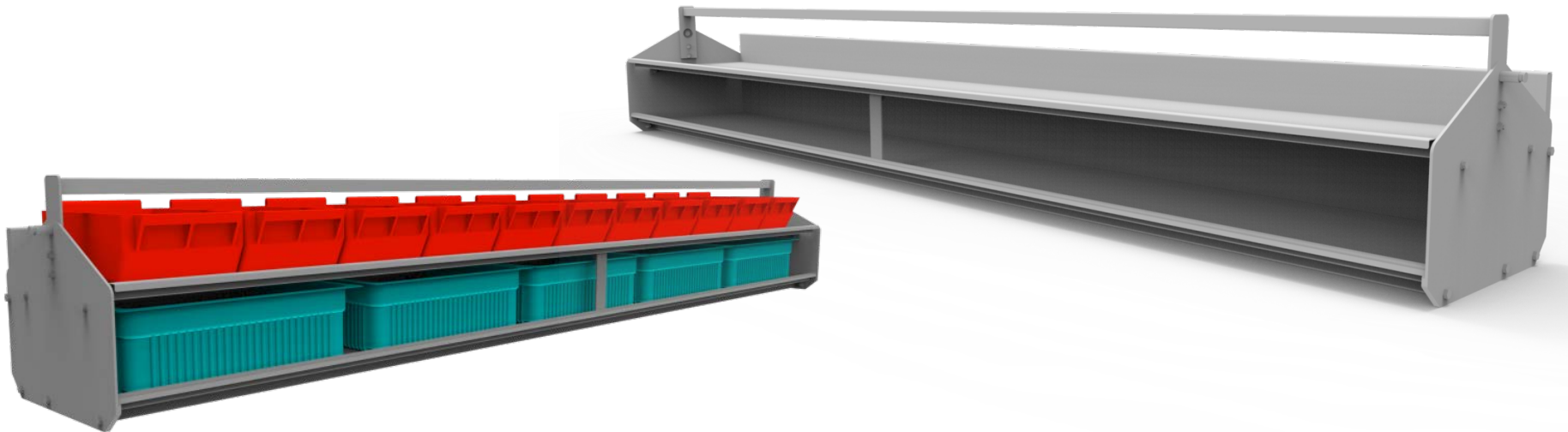

Safe Handling • Easy Access • Maximum Storage • Fast Retrieval • Small Footprint

Shelving Carriers Sizes

Description	Width	Depth	Height	C. Capacity	Weight
8' Shelving Carrier	8' 8"	1' 8"	1' 6.5"	1,000 lbs.	197 lbs.
12' Shelving Carrier	12' 8"	1' 8"	1' 6.5"	1,000 lbs.	256 lbs.
8' HD Shelving Carrier	8' 8"	1' 8"	1' 6.5"	2,500 lbs.	260 lbs.
12' HD Shelving Carrier	12' 8"	1' 8"	1' 6.5"	2,500 lbs.	385 lbs.
8' Intermediary Shelf	8' 8"	1' 8"	1' 6.5"	NA	78 lbs.
12' Intermediary Shelf	12' 8"	1' 8"	1' 6.5"	NA	104 lbs.

Safe Handling • Easy Access • Maximum Storage • Fast Retrieval • Small Footprint

Shelving Carriers Custom Configurations

Carriers can be custom designed to accept unique profiles and handling procedures to accommodate heavier and bulkier items that do not conform to conventional storage systems.

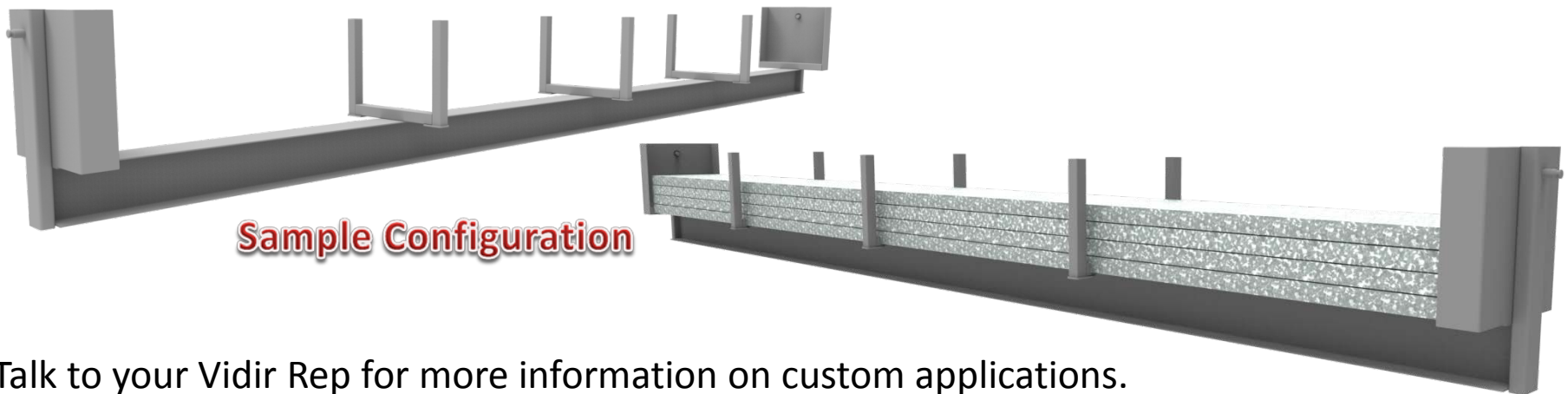

Talk to your Vidir Rep for more information on custom applications.

Safe Handling • Easy Access • Maximum Storage • Fast Retrieval • Small Footprint

Shelving Carriers Custom Configurations

There is a very large range of materials and products that can be stored.

On the following slides you will see some examples of custom applications.

**Please contact your Vidir Rep
for more information on customization.**

Safe Handling • Easy Access • Maximum Storage • Fast Retrieval • Small Footprint

Custom Application Examples

???

Safe Handling • Easy Access • Maximum Storage • Fast Retrieval • Small Footprint

Custom Application Examples

Bobbin Carousel

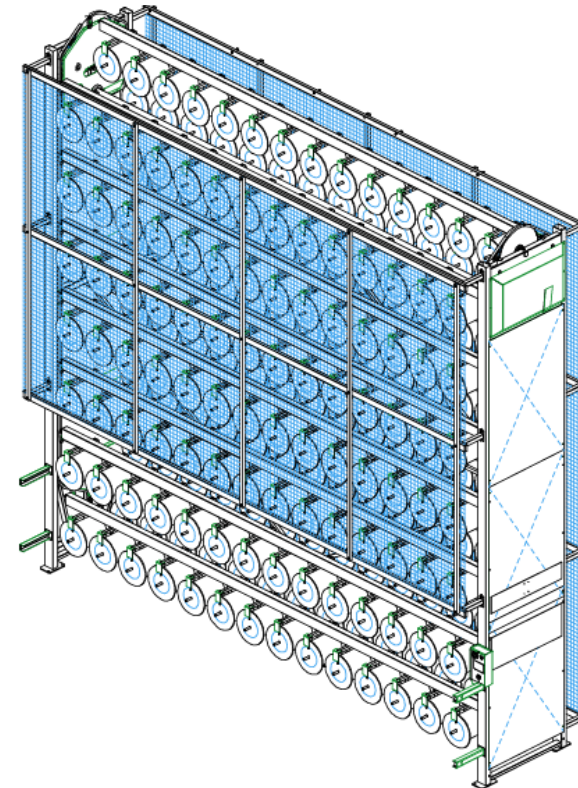
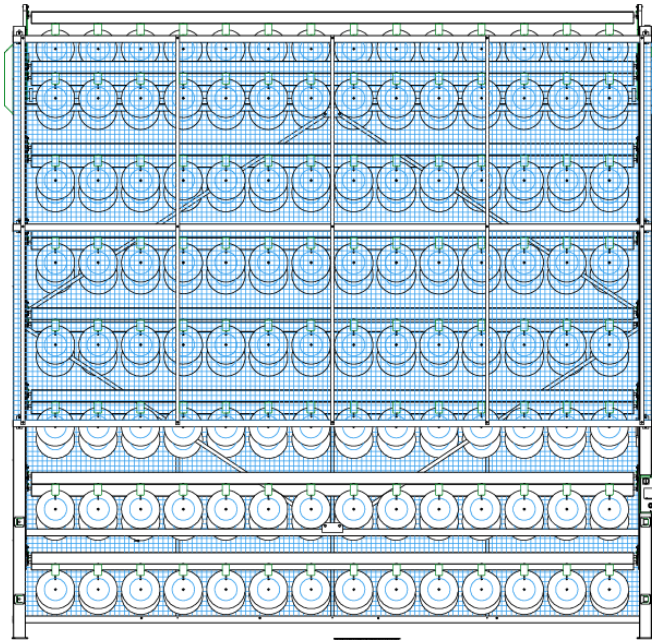

Safe Handling • Easy Access • Maximum Storage • Fast Retrieval • Small Footprint

Custom Application Examples

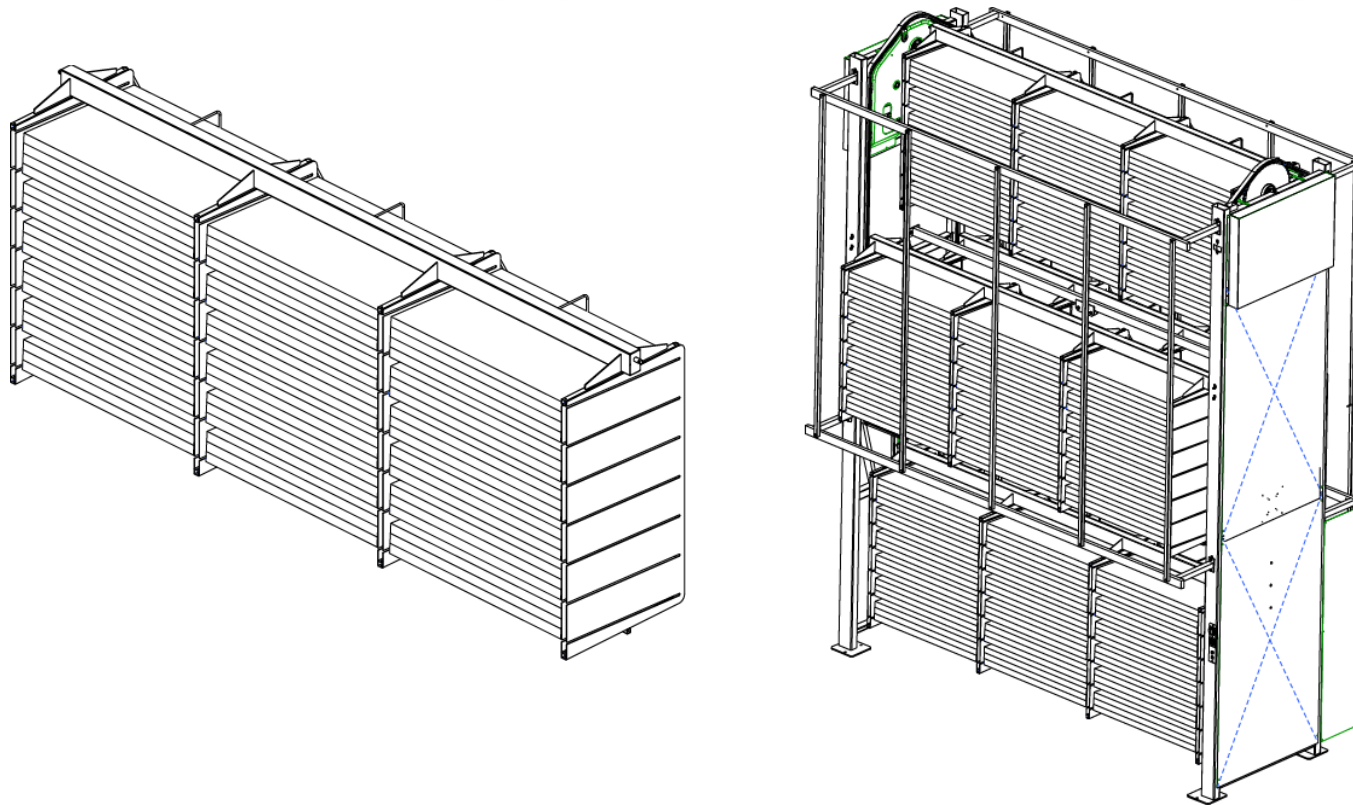

Safe Handling • Easy Access • Maximum Storage • Fast Retrieval • Small Footprint

Custom Application Examples

12 foot Divided Carrier

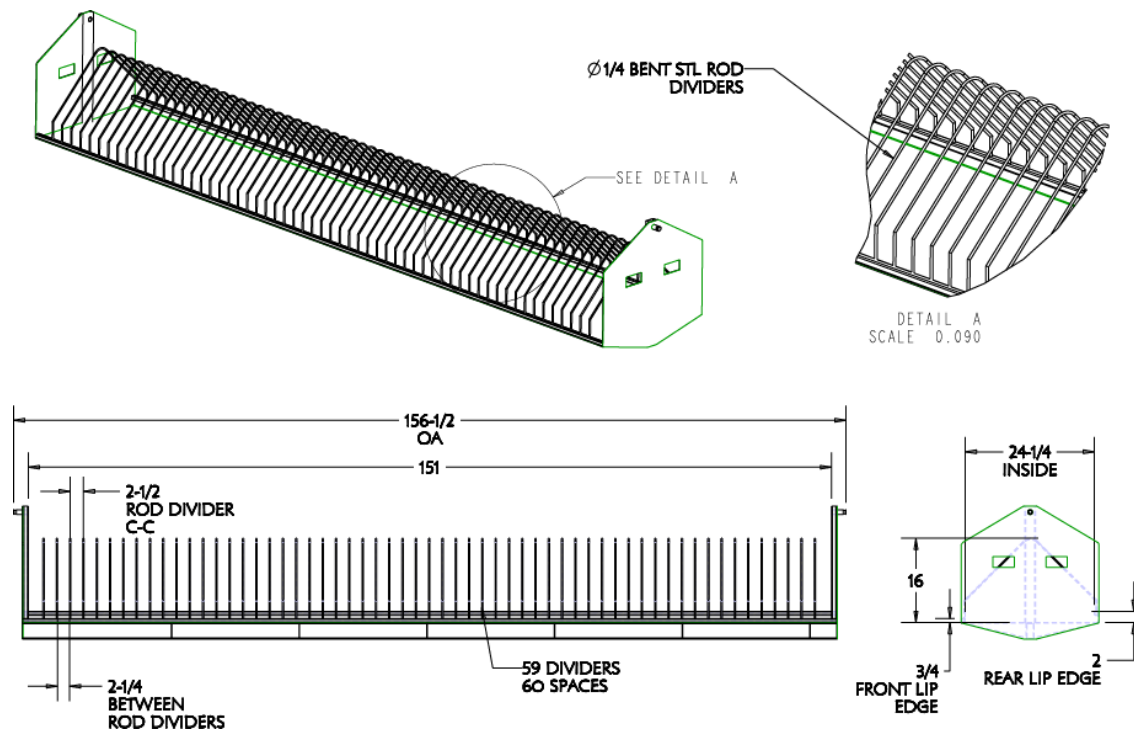

Safe Handling • Easy Access • Maximum Storage • Fast Retrieval • Small Footprint

Custom Application Examples

Cylinder Carousel

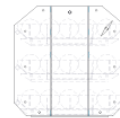

15 CYLINDERS
PER CARRIER
5 PER LEVEL

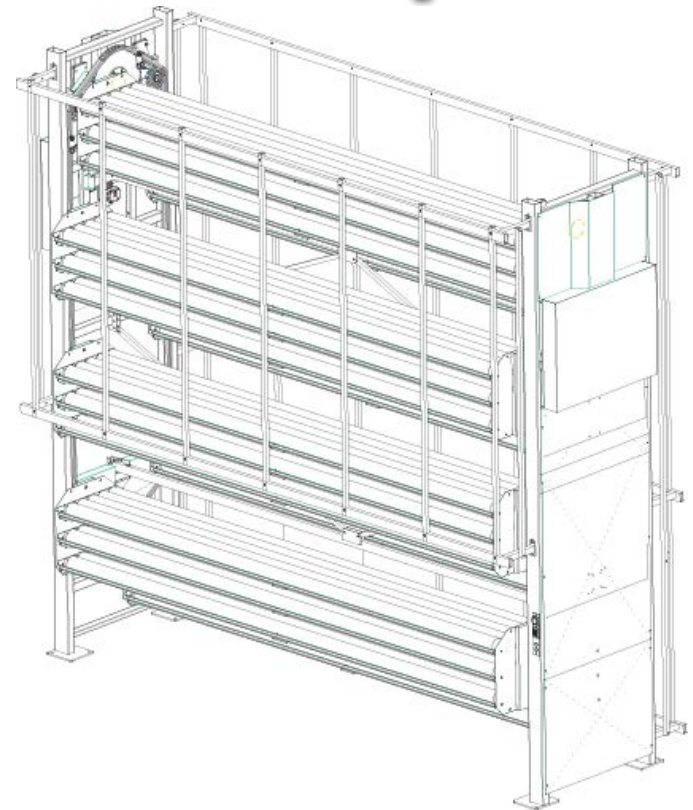

Safe Handling • Easy Access • Maximum Storage • Fast Retrieval • Small Footprint

What Type of Product?

Physical Dimensions of Parts/Container

- ✓ *Height*
- ✓ *Depth*
- ✓ *Width*
- ✓ *Weight*

Quantity per Parts/Container



Safe Handling • Easy Access • Maximum Storage • Fast Retrieval • Small Footprint

***Plan for growth
when recommending
equipment!***

**20-30%
extra capacity**



Safe Handling • Easy Access • Maximum Storage • Fast Retrieval • Small Footprint

Retrieval Times



- ✓ Retrieval time is defined as the time it takes to get the desired material to where you need it.

Carousel Automation

- Required for more advanced inventory management systems
 - Includes frame extensions, safety light curtains, a programmable PLC, and a more advanced controller than the push buttons that come standard
 - Allows the customer to integrate carousel functions into their own ERP or WMS systems
- 
- Built in safeties to shut the carousel off if something enters the carousel's path

Safe Handling • Easy Access • Maximum Storage • Fast Retrieval • Small Footprint

Inventory Control Solutions Small Business Solution

Designed for small business but easily scalable, our complete inventory control system consists of a touch screen controller (PLC), and bar code scanning. Additionally our intuitive inventory control software is integrated within the processor on the PLC and allows the inventory on the carousel to be easily managed and monitored.



Safe Handling • Easy Access • Maximum Storage • Fast Retrieval • Small Footprint

Inventory Control Solutions Enterprise Solution

For organizations with an already established enterprise management solution, our carousels integrate seamlessly with other “off the shelf” or custom inventory solutions through the Vidir API. The API functions as a gateway from our hardware to the clients software. We supply the necessary command codes to program into your application, which allows the client to set the behaviors of the carousels as well as control how it interacts with the world around it.



Safe Handling • Easy Access • Maximum Storage • Fast Retrieval • Small Footprint

Inventory Control Solutions VIS Solution

This software solution was designed for organizations that do not require a full inventory management solution but wish greater control of their carousels. The Vidir Inventory Software (VIS) is a standalone purchase that is required to be installed on a terminal within the same local network as the carousels they are controlling. The terminal must be running a Windows operating system.



Safe Handling • Easy Access • Maximum Storage • Fast Retrieval • Small Footprint

Vidir Inventory Control (VIC)



Vidir's Inventory Control was built in-house from the ground up to efficiently track and manage inventory across all of Vidir's Carousels.

Features:

- ✓ Order Picking and Fulfillment
- ✓ Product Identification
- ✓ Pick/Stock Lists
- ✓ Transaction History
- ✓ Bin Management
- ✓ Pick to Light Support
- ✓ Reporting
- ✓ Real Time Inventory Counts
- ✓ Multiple Zone Picking
- ✓ Multi-Carousel Support
- ✓ User Access Controls

Part #VIS1-2.0
See price list.

Safe Handling • Easy Access • Maximum Storage • Fast Retrieval • Small Footprint

Heavy Duty Upgrade - Optional

Increases the overall weight capacity to 34,000 lbs., the carrier capacity to 2,500 lbs., and the unit imbalance to 3,000 lbs. Should be considered for applications with a duty cycle greater than 50%.

See price list.

Safe Handling • Easy Access • Maximum Storage • Fast Retrieval • Small Footprint

Bar Code Scanners - Optional



Bar code functionality is included in the 'Small Business Solution' or can be integrated separately with clients inventory management system.

Part #400-0133
See price list.

Safe Handling • Easy Access • Maximum Storage • Fast Retrieval • Small Footprint



See price list.

Full Enclosure - Optional

The full enclosure replaces the mesh on the front and rear with solid paneling as well as adding an enclosed ceiling. This option is usually purchased for either the security, fire suppression, or to protect product.

Safe Handling • Easy Access • Maximum Storage • Fast Retrieval • Small Footprint

Dual Controls - Optional

Add a duplicate control center to the left tower of the carousel enabling control from either side to increase retrieval speeds



See price list.

Safe Handling • Easy Access • Maximum Storage • Fast Retrieval • Small Footprint

Touchscreen Computer – Optional

A HD 23" LED multi-touch desktop. This industrial touchscreen can be ordered independently or as part of the 'Small Business Solutions' package.

Part #409-0142
See price list.



Safe Handling • Easy Access • Maximum Storage • Fast Retrieval • Small Footprint

RAL Color - Optional

The primary color on Vidir carousels is white with grey carriers.

We can supply up to 76 additional RAL'S for a moderate upcharge. Per request we can also match customer paint chips.



See price list.



Sample Colors

Safe Handling • Easy Access • Maximum Storage • Fast Retrieval • Small Footprint



**ALL freight is
handled by
Vidir carriers**

Carousels ship knocked down and
need to be assembled on-site by a
trained installation team.

Safe Handling • Easy Access • Maximum Storage • Fast Retrieval • Small Footprint

Installation Program

- ✓ Needs to be done by a factory certified installer
 - ✓ Certification can happen on the job
- ✓ Pan Carousels, Bedlift, and MMB require separate training
- ✓ Training sessions can be done in our facility in Lebanon, PA with enough interest in early 2017.

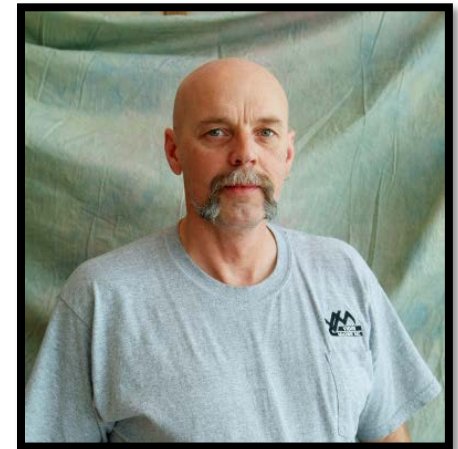

Dave Martens
Installation
Manager

Installation

1. Get installation information during your site visit.
 - I. Do they have a loading dock?
 - II. Is there a clear path to the installation location from the unloading area?
 - III. Suitable concrete floor for anchoring?
 - IV. Special training/equipment required?
2. Shelving Carousel installation takes approximately 8 hours for 2 installers
3. The electrical needs to be run prior to the carousel being installed
4. Forklifts and Scissorlifts need to be supplied
5. Equipment usage training is provided



Safe Handling • Easy Access • Maximum Storage • Fast Retrieval • Small Footprint

Replacement Parts

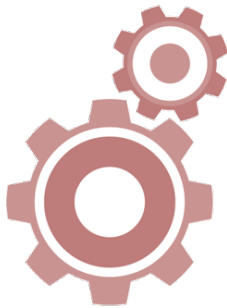

For replacement parts please call

Vidir Service

at

866.821.2647



Safe Handling • Easy Access • Maximum Storage • Fast Retrieval • Small Footprint



**Please contact your Vidir rep for
more information about any details
on this webinar by calling
1-800-210-0141**



Safe Handling • Easy Access • Maximum Storage • Fast Retrieval • Small Footprint

Toll Free: 800.210.0141 www.storevertical.com